

Sterling's V-BELT DRIVE BLOWERS

Ultra High Efficiency...Built to Last

Quality Design

- Housing and base feature all-welded, heavy gauge steel construction with hand finished interior to prevent material build-up and contamination.
- TEFC dual wound motor with shaft seal standard on all models.
- All drive components and safety guards are included with assembly.
- Housing, impeller, or motor easily replaced if worn or damaged.

Durable

- Unique design features make blower ideal for rugged material handling applications.
- Also available in our Diamond Line Series...THE answer to abrasive material applications such as hard plastics, glass-filled materials, rubber, etc.

Versatile

- Blowers are custom-designed to meet the customer's application.
- Sixteen different discharge positions available for all models.
- Optional stainless steel construction available for all models.
- Sound enclosures and silencers are available to quiet the operation of the unit.
- Components for sizes 4-8 are stocked, offering the quickest available delivery in the industry.
- V-Belt Drive blowers offer a range of CFM capabilities through a simple sheave/bushing change.
- Universally recognized components—motors, belts, bearing, sheaves and bushings—are used for fast and economical replacement.



STERLING **SYSTEMS**
A Division of Sterling Blower Company

Sterling
Blower Company

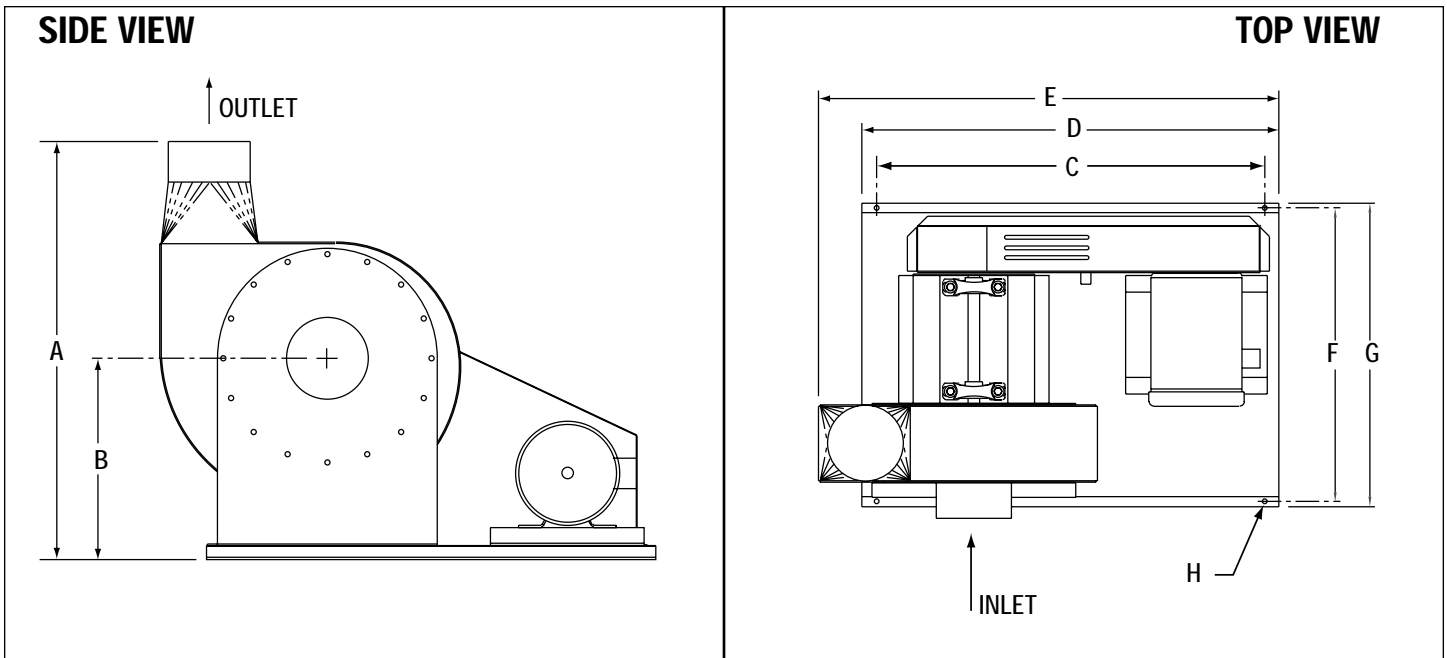

Standard inlet and outlet diameters are supplied unless otherwise specified. • All dimensions are in inches. • Dimensions are approximate; consult factory for certified drawings.

STANDARD DIMENSIONS

| BLOWER SIZE | A | B | C | D | E | F | G | H | WHEEL DIAMETER | STANDARD HPs |
|-------------------------------|--------|--------|--------|--------|--------|--------|--------|------|----------------|--------------|
| #4 4001FV 4002FV | 24 1/4 | 10 1/2 | 23 | 26 | 28 1/4 | 22 1/4 | 23 1/4 | 9/16 | 9 1/2 | 1,2 |
| #5 5003FV 5005FV | 28 1/4 | 13 1/2 | 33 | 36 | 38 1/4 | 25 | 26 | 9/16 | 11 7/8 | 3,5 |
| #6 6005FV 6075FV | 32 1/4 | 16 | 33 | 36 | 39 1/4 | 27 | 28 | 9/16 | 14 1/4 | 5,7 1/2 |
| #7 7075FV 7010FV | 35 1/2 | 17 3/4 | 38 3/4 | 41 3/4 | 45 1/4 | 30 | 31 | 9/16 | 16 5/8 | 7 1/2, 10 |
| #8 8010FV 8015FV 8020FV | 40 3/4 | 19 3/4 | 41 | 44 | 48 3/4 | 31 | 32 | 9/16 | 19 | 10,15,20 |
| #9 9010FV 9015FV 9020FV | 40 3/4 | 19 3/4 | 41 | 44 | 48 1/4 | 31 | 32 | 9/16 | 19 | 10,15,20 |
| #11 1120FV 1125FV | 47 | 21 3/4 | 31 | 47 | 53 | 35 1/2 | 36 1/2 | 9/16 | 22 | 20,25 |
| #13 1325FV | 53 1/4 | 25 3/4 | 44 1/2 | 47 1/2 | 58 1/4 | 39 | 40 | 9/16 | 26 | 25 |
| #15 1525FV 1530FV | 59 | 29 1/4 | 54 1/4 | 57 1/4 | 64 1/2 | 49 1/2 | 50 1/2 | 9/16 | 30 | 25,30 |

Standard Discharge Positions (view from drive side)

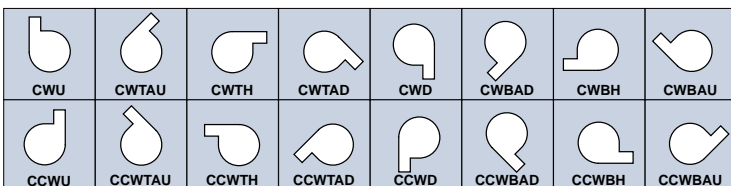

135 Vista Centre Dr.
Forest, VA 24551-3964
(434) 316-5310 • Fax: (434) 316-5910

www.sterlingblower.com
sterling@sterlingblower.com