

Sterling's DIRECT DRIVE BLOWERS

Ultra High Efficiency...Built to Last

Quality Design

- Housing and base feature all-welded, heavy gauge steel construction with hand finished interior to prevent material build-up and contamination.
- TEFC dual wound motor with shaft seal standard on all models.
- Housing, impeller, or motor easily replaced if worn or damaged.

Durable

- Unique design features make blower ideal for rugged material handling applications.
- Also available in our Diamond Line Series...THE answer to abrasive material applications such as hard plastics, glass-filled materials, rubber, etc.

Versatile

- Blowers are custom-designed to meet the customer's application.
- Sixteen different discharge positions available for all models.
- Optional stainless steel construction available for all models.
- Sound enclosures and silencers are available to quiet the operation of the unit
- All components are stocked, offering the quickest available delivery in the industry.



Sterling
blower company



STERLING SYSTEMS
A Division of Sterling Blower Company

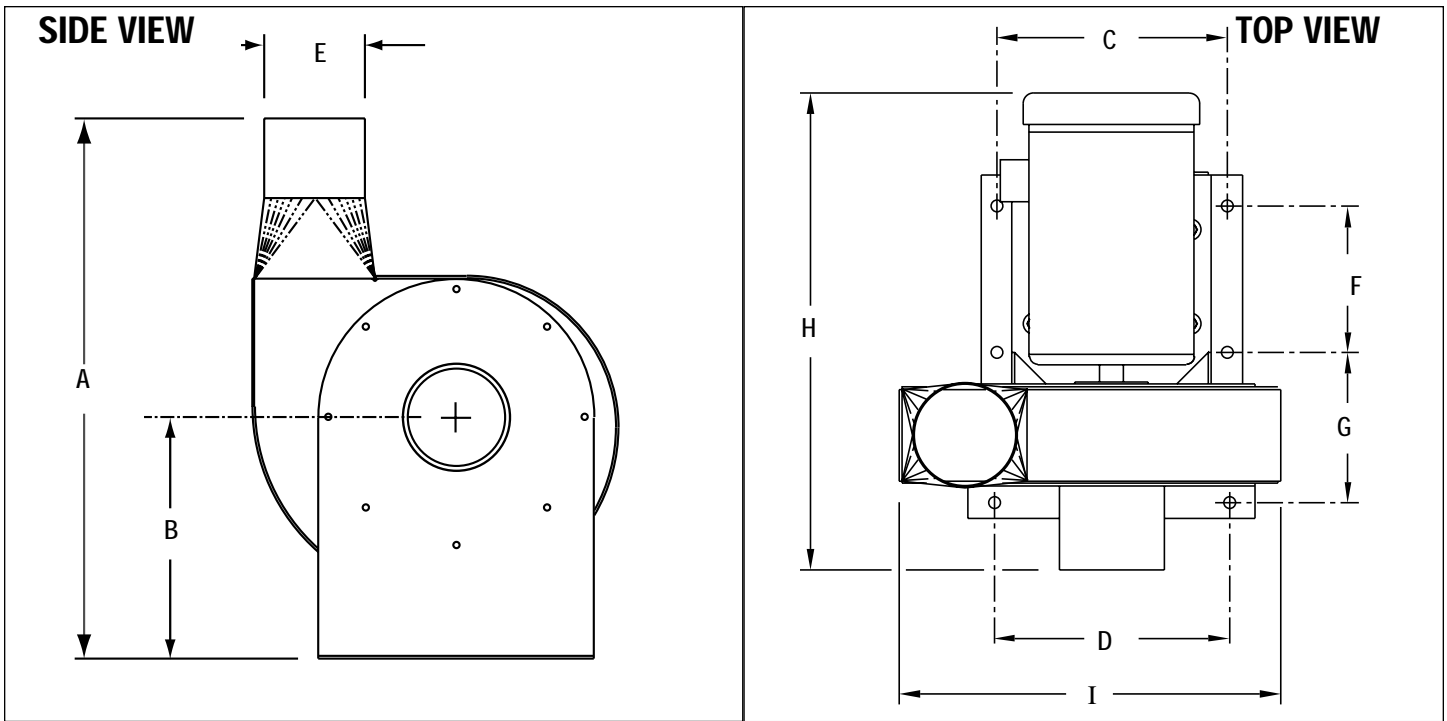

Standard inlet and outlet diameters are supplied unless otherwise specified. • All dimensions are in inches. • Dimensions are approximate; consult factory for certified drawings.

STANDARD DIMENSIONS

BLOWER SIZE	A	B	C	D	E	F	G	H	I	HP
4001FD	22 ⁷ / ₈	9 ¹ / ₈	9 ¹ / ₄	—	4	5 ³ / ₈	—	18	14 ⁷ / ₈	1
4002FD	22 ⁷ / ₈	9 ¹ / ₈	9 ¹ / ₄	—	4	5 ³ / ₈	—	19 ³ / ₄	14 ⁷ / ₈	2
5003FD	26 ⁷ / ₈	12	11	11 ¹ / ₄	5	7	7 ¹ / ₄	21 ¹ / ₂	18 ¹ / ₄	3
5005FD	26 ⁷ / ₈	12	11	11 ¹ / ₄	5	7	7 ¹ / ₄	22 ⁷ / ₈	18 ¹ / ₄	5
6005FD	30 ⁷ / ₈	14 ¹ / ₂	13 ³ / ₄	12	6	9 ¹ / ₈	7 ⁷ / ₈	24 ¹ / ₈	22 ¹ / ₈	5
6075FD	30 ⁷ / ₈	14 ¹ / ₂	13 ³ / ₄	12	6	9 ¹ / ₈	7 ⁷ / ₈	24 ³ / ₄	22 ¹ / ₈	7 ¹ / ₂
7005FD	34	16 ¹ / ₄	11 ³ / ₈	12 ³ / ₄	7	9 ¹ / ₂	8 ³ / ₈	24 ¹ / ₂	25 ¹ / ₄	5
7075FD	34	16 ¹ / ₄	11 ³ / ₈	12 ³ / ₄	7	9 ¹ / ₂	8 ³ / ₈	25 ¹ / ₂	25 ¹ / ₄	7 ¹ / ₂

Standard Discharge Positions (view from drive side)

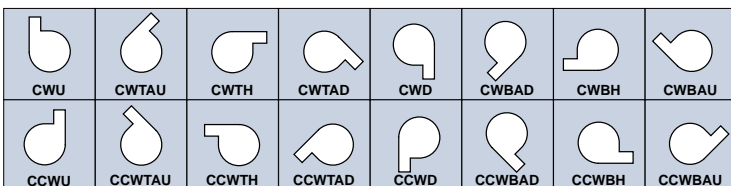

135 Vista Centre Dr.
 Forest, VA 24551-3964
 (434) 316-5310 • Fax: (434) 316-5910

www.sterlingblower.com
 sterling@sterlingblower.com